

PIRATE QUEEN

(5 REELS 10 LINES VIDEO X VGA SLOT GAME)

A style new edition of SUBSINO Video 5-reels and 10-lines slot game - Vertical-Monitor 16:9 format.

Full of new enhancements, animated graphics and enhanced sound, Pirate Queen is sure to fashion and delivers a winning combination.

HOW TO PLAY

- Insert coin(s) or bill(s).
- Press [Bet] to bet one credit for each select line. Or, press [Max Bet] for max bet and begin.
- Then press [Start] button to spin the reels. Press [Stop1], [Stop2], [Stop3], [Stop4] or [Stop5] to stop the reel or [Start] button again to stop all reels.
- When you have any win combination, you win. Press [Take Score] to take winning score into Credit, or press [Double Up], [Half Double] or [Re-Double] to play Double Up game. If Double-Up function is disabled, the system will take scores automatically.
- Press [Help] to check the result of last game and relative game information. Or, select Denomination value when the function is available.



Main Game



Double Up

GAME FEATURES

- GHOST CAPTAIN SYMBOL: Ghost Captain is wild as joker to replace any symbols, except Spin Fever and Treasure Chest Symbol.
- GREAT REEL BONUS: Wagering Fortune Reel when over three 'Spin Fever' symbols hits on any position. It's time for serious award and Jackpot fun. Initiate big Fortune Reel and break the winning by you.

The prizes contain Black JP (Jackpot), Red JP (Jackpot), max 600 times prize.

GESTURE TOUCH available!!

- FREE PLAY: Stare over three 'Treasure Chest' symbols land in any position and trigger Free Play Bonus.

3 Treasure Chest – Free Play 7 Times
 4 Treasure Chest – Free Play 12 Times
 5 Treasure Chest – Free Play 20 Times



Great Reel Bonus



Free Play

INSTALLATION

1) MAIN PCB

- Make sure you have powered-off game.
- Mount 'Game PC Board' on the cabinet.
- Connect 36pin and 10 pin edge connector of the cabinet to Edge connectors (36pin & 10 pin) of 'Game PC Board'. Refer Page 12 for the diagram of Connector.

2) MONITOR

- Make sure the monitor (CRT/LCD) supports 1366x768 resolutions.
- Connect monitor connector to the monitor socket (VGA D-Sub) of 'Game PC Board'.

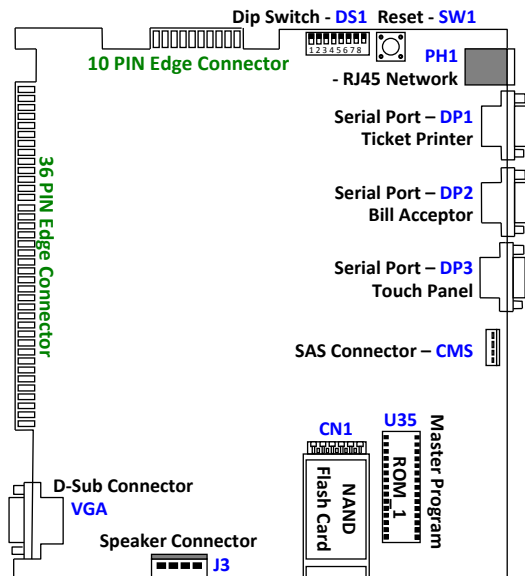

3) SPEAKER

- Audio Amplifier of hardware is newest powerful stereo Amplifier. It uses 2 set separate speakers for Audio Out. Connect two speakers to (R+:R-) and (L+:L-) of J3.
- Don't connect any of "Audio Out" to Ground (GND) or link directly the speaker to Ground. In the case of wrong Ground linkage, it will cause PC Board (hardware) damage.
- The 20watt, 8 ohm speaker and more is recommended. If the power of speaker doesn't enough, the "distortion" may find when audio out.

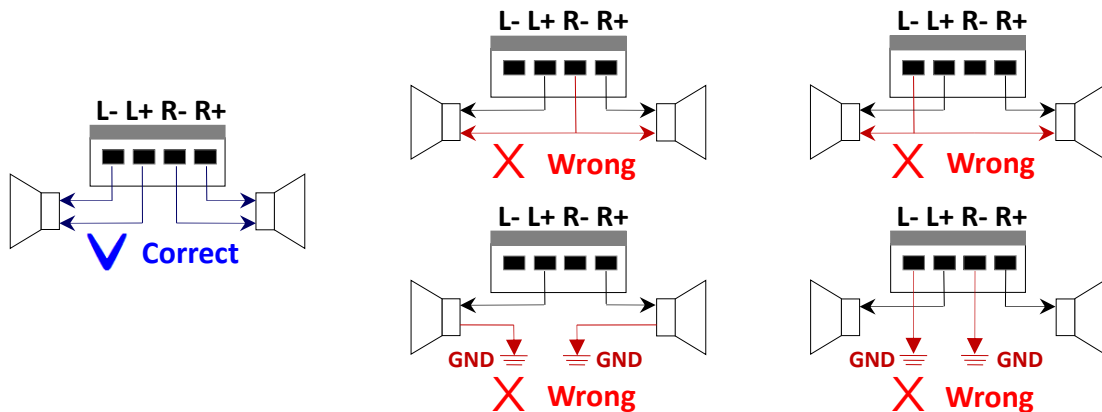

4) TOUCH PANEL

- It's optional and shows relative function automatically after connect.
- Make sure (a) The panel is 3M Microtouch panel or compatible. (b) Connect to DP3 – Touch Panel port. (c) Touch Screen function in Game Setup B of Test/ Setup set to "Enable" to activate. (d) Power Off and On again to ensure the setup is available. The screen will show relative buttons and function this moment.
- Calibrate: Press [Test/ Setup] on the cabinet to go to "Test/ Setup Mode" and select "Touch Screen Calibrate". Touch a Cross symbol for two times to calibrate.

5) BILL ACCEPTOR (SERIAL TYPE)

- The game is available to use both pulse and serial type of Bill Acceptor.
- If use serial type of Bill Acceptor as JCM WBA/ UBA or compatible, adjust Dip Switch Dip#1 to ON and link the connector of Bill Acceptor to DP2 – Bill Acceptor.

6) TICKET PRINTER AND SAS PROTOCOL

Both Ticket Printer (DP1) and SAS Protocol (CMS) are unavailable in the version, and supports in specific version only.

7) CONTROL PANEL

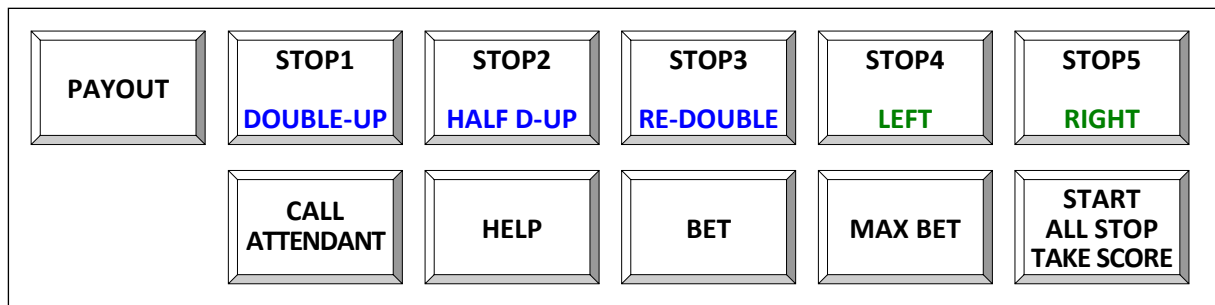

Establish above buttons on the panel. Refer the page of Connector Diagram.

- ▶ STOP1/ DOUBLE, STOP2/ HALF DOUBLE, STOP3/ RE-DOUBLE, STOP4 / LEFT, STOP5 / RIGHT
 - a. Stop the reel by Stop1, Stop2, Stop3, Stop4 and Stop5.
 - b. Choice D-Up Mode (Double, Half Double or Re-Double) and Play (Left or Right).
- ▶ START/ ALL STOP/ TAKE SCORE
 - a. Begin the game and again to stop all reels.
 - b. Take winning score after won.
- ▶ BET: To bet one credit per push for each line.
- ▶ MAX BET: To wager max value of bet and start the game.
- ▶ HELP: Check last game and game features before the player bets.

8) POWER ON AND CHECK

- After you do all of above, please power on the game. Check +5V DC on main PCB side. The voltage between +4.95 to 5.05V DC is good.
- Press [Test/ Setup] on the cabinet to go to “Test/ Setup Mode”.
- Refer Page 4 to 7 of “Test/ Setup Mode” to set each setting.
- Also, check each function and movement in Test/ Setup Mode. (All buttons & lamps, TV size and color adjustment ... etc.)
- Please refer to page 11 of “Error” or “Troubleshooting” if you have any problems or malfunctions.

TEST AND SETUP

If you need to check the condition of the game circuitry, controls or set system value, you can use the Test/ Setup Mode.

Power ON and Press [Test/ Setup] key will go to the mode, as right.

- Moving the bar by pressing [Stop1] button. After choosing one of the contents with the bar, press [Stop5] to enter.
- Press [Start] to exit and back to game mode of main screen. In the case, the value you adjusted would available instantly, which don't necessary to turn off the power.

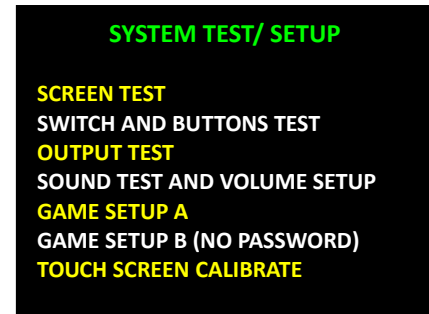

1) SCREEN TEST

- Use this screen to check the color of monitor and the size of pictures.
- The color bands in the center should be Red, Green, Blue and White from left to right.
- The Cross Hatch test pattern has a white grid on a black background. The check as follows:
 - ▶ The grid line should be straight, and the lines should not have excessive pincushion or barrel distortion.
 - ▶ “Out” line of grid line is same size as “Out” line of game screen, which should able to be seen without overflow of grid lines on screen.
- If the screen does not match above description, adjust the monitor as described in the monitor’s manual.
- Press [Start] button to back main menu.

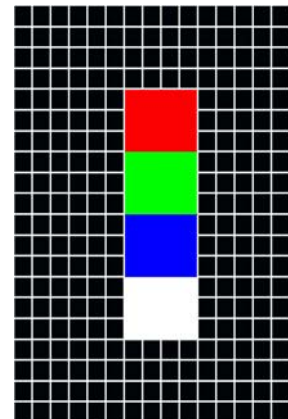

2) SWITCH AND BUTTONS TEST

Use this screen to check the buttons and switch in this game.

- To check the functioning of each button and switch, activate it and watch the corresponding “OFF” letters change to “ON”. If the “ON” and “OFF” letters don’t appear correctly, check the hardness connections and switches.
- Press [Start] button to back main menu.

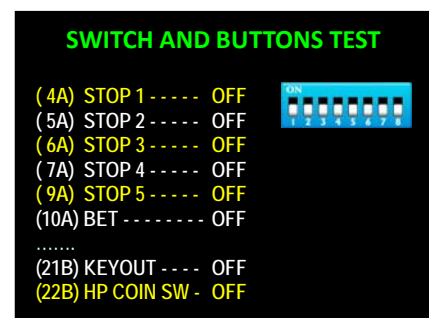

3) OUTPUT TEST

Use this screen to check the lamp of buttons in this game.

- To check the functioning of each output, including Counters and lamp of button. Press [Stop1] to move and press [Stop5] to test as watch the corresponding lamp ON.
- Counters, Bill Inhibit, Coin Inhibit and HP Full Out are to test the action, no lamp.
- Press [Start] button to exit.

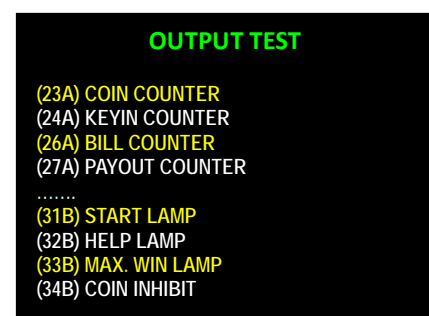

4) SOUND TEST AND VOLUME SETUP

Use this screen to check all game sounds and setup the volume as soft volume control.

- Adjust the volume by pressing [Stop1] to decrease and [Stop2] to increase.
- Choice a sound by pressing [Stop3] button (previous) or [Stop4] button (next), and the machine will make a sound in the moment.
- Press [Start] button to back main menu.

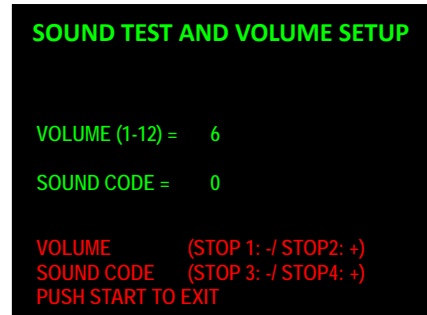

5) GAME SETUP A

The setup items are important and operated by important person as owner only. The password is necessary before enter the screen of Game Setup A. The default value is 111111 (six 1) and enable to change in same password screen.

- [Stop1] button for 1; [Stop2] button for 2;
 [Stop3] button for 3; [Stop4] button for 4;
 [Stop5] button for 5;

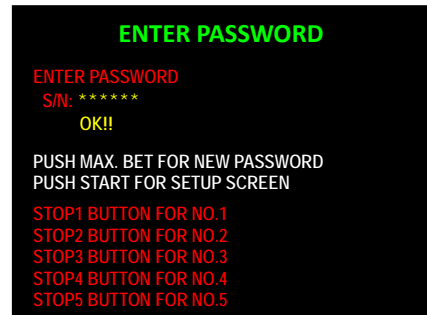

When the password input with correct, “OK!” is shown on the screen. To change new password, press [Max Bet] button and input new password as you want. Or, press [Start] button to enter ‘Game Setup A’.

Use the screen to manually adjust the game setting.

- Moving the bar by pressing [Stop1] button. Select the setting value by pressing [Stop5] button.
- Press [Start] button to back main menu. In the case, the value you adjusted would available instantly, which don't necessary to turn off the power.

CONTENTS	SETTING SELECTION (Underline item is default)
COIN	1, 2, <u>5</u> , 10, 20, 25, 50, 75, 100, 200, 300
KEYIN	1, 2, <u>5</u> , 10, 20, 25, 50, 75, 100, 200, 300, 500
PAYOUT	1, 2, <u>5</u> , 10, 20, 25, 50, 75, 100, 200, 300
KEYOUT	1, 2, <u>5</u> , 10, 20, 25, 50, 75, 100, 200, 300, 500
BILL IN	1, 2, <u>5</u> , 10, 20, 25, 50, 75, 100, 200, 300, 500
MIN. BET	1, <u>5</u> , 10, 20, 40, 60
MAX. BET	100, 200, 300, <u>400</u>
WIN RATE	90, 91, 92, 93, 94, <u>95</u> , 96, 97, 98
GAME LIMIT	5000, 10000, 20000, 30000, 40000, 50000 <u>60000</u> , 80000, 100000, 150000, 200000
WIN RATE WAVE	<u>NORMAL</u> , HIGH
DOUBLE FUNCTION	<u>ENABLE</u> , DISABLE
HALF-DOUBLE	<u>ENABLE</u> , DISABLE
RE-DOUBLE	<u>ENABLE</u> , DISABLE
DOUBLE RATE	94, 95, <u>96</u> , 97, 98, 99
DOUBLE LIMIT	5000, 10000, 20000, 30000, 40000, 50000, 60000, 80000, 100000
MIN. JACKPOT BET	10, 20, 30, 40, 50, 60, 70, 80, 90, 100

- a. Coin: Adjust how many credits per insert coin.
- b. Keyin: Adjust how many credits per Keyin.
- c. Payout: Adjust how many credits per pay coin.
- d. Keyout: Adjust how many credits per pay Step when Keyout.
- e. Bill In: Adjust how many credits per Bill signal.
- f. Min Bet: Adjust how many min bets to start the game.
- g. Max Bet: Adjust how many max bets can bet at one play.
- h. Win Rate: Adjust total rate % of game.

The win Rate is calculated and defines as follows:

$$\text{Win Rate} = \frac{\text{Total Won Score}}{\text{Total Played Score}}$$

Since this is quite different from some games, which defined the rate as “Coin Out” divided by “Coin In” (Usually call Payout Rate). You shouldn't set the win rate at the same value used in the games. In our experience, the ideal Win Rate is 94%.

Please don't RESET except necessary. To stabilize the rates, the game should operate a period (more long, more steady) for the balance as setup.

- i. Game Limit: Adjust how many credits game can hold.
- j. Win Rate Wave: It's to assign the prizes and rate. Big wave has more big prizes and focus more win or lose. Small wave has more small prizes and rate with more steady.
- k. Double Func.: Play D-Up game when Main Game won. The play score in D-Up is winning score in main game.
- l. Re-Double: The play score in Double Up is twice winning score in main game.
- m. Half Double: The play score in Double Up is a half of winning score in main game.
- n. Double Rate: The rate of D-Up game and defines as Win Rate.
- o. Double Limit: To limit the winning score in Double Up. The system will take the score automatically when winning score is over Double Limit.
- p. Min. Jackpot Bet: Min Bet to win the Jackpot.

6) GAME SETUP B (NO PASSWORD)

The setup items are general ones and can operate by the staff in field. The password is unnecessary for the function of Game Setup B. Use the screen to manually adjust the game setting.

CONTENTS	SETTING SELECTION (Underline item is default)
TOUCH SCREEN	ENABLE, DISABLE
DEMO MUSIC	ENABLE, DISABLE
DEMO SHOW	ENABLE, DISABLE
KEYOUT TYPE	ZERO, REST
MAX. PAY TOKENS	200, 300, 400, 500, 1000, FREE
BILL INHIBITION	N.C., N.O.
HOPPER SW TYPE	N.C., N.O.
AUTO PLAY	ENABLE, DISABLE

- a. Touch Screen: To enable or disable Touch Function.
- b. Demo Music: To enable or disable demo music.
- c. Demo Show: To enable or disable demo function.
- d. Keyout Type: Adjust Keyout should take to 0 (zero) or under one Keyout value (rest).
- e. Max Pay Tokens: Adjust max coins are paid, which to avoid the hopper empty.
- f. Bill Inhibition: For Bill Acceptor. N.C. - Normal close (low), N.O. – Normal Open (Hi).
- g. Hopper Sw. Type: For Hopper. N.C. - Normal close (low), N.O. – Normal Open (Hi).
- h. Auto Play: To enable or disable play automatically.

7) TOUCH SCREEN CALIBRATE

The item appears only when Touch Panel was connected. It's to calibrate the touch position. Enter the item and touch a Cross symbol for two times to calibrate.

8) DIP SWITCH FUNCTION

Except Screen Setup, some of functions are defined and setup from Dip Switch of PC Board, as follows:

DIP SWITCH		1	2	3	4	5	6	7	8
BILL ACCEPTOR	Serial Pulse	ON OFF	JCM bill acceptor or compatible						
DOOR OPEN	N.C. N.O.		ON OFF						
HOPPER PULSE (Milli-Second)	30 ms 40 ms 50 ms 60 ms			OFF ON OFF ON	OFF OFF ON ON				

BOOK

Press [Book] button to enter Book screens. Press [Stop5] to enter next page and [Stop1] for previous page. Press [Start] button to back normal game.

First Page



The page shows the records from last “check out”.

Total Times: Total played times.

Total Played: Total played score.

Total Won: Total won score.

“Check Out”: To clear this page. Please refer Page 9, Reset function for Clear Current Record Only.

Second Page



The Score column of top form shows the score of Coin, Payout, Keyin, Keyout, Bill In and Net.

The Counter column shows "System Counters". It didn't able to clear by anyway and affected by Reset function, which to compare relatively with machine's mechanical counters when “check out each time”.

(Total/ Main/ Double) Played & Won

Played scores and Won scores in Total/ Main game/ Double game.

(Total/Double) Play Times & Win Times

Played times & Win times in Total/Double game.

Power Times: The times of Power ON.

Third Page

The page shows win times and score of Bonus and JP.



(Spin Fever/ Treasure Chest/ Free Play) Times & Score

Win times and score of Spin Fever, Treasure Chest and Free Play

(Jackpot Red - Black) Times & Score

Win times and score of Red and Black Jackpot.

Fourth & Fifth page

Both pages show win times of each prize.



RESET (Clear)

● CLEAR ALL

Turn off the power. Turn on [Book] and [Setup] key simultaneously and then turn on the power. (If [Book] or [Setup] make by the buttons, you should press without release.)

The screen will show “System Reset”, which means all of Book data have cleared and game setup values have changed to default value. ("System Counters" in the second page of Book remain unchanged and cleared to zero.).

- ▶ RESET button on the board is unavailable in current version.
- ▶ You should do RESET if you change the Master Rom (Rom_1) or after changed the Win Rate.

● CLEAR CURRENT RECORD ONLY (CHECK OUT)

Turn on [Book] Key (or press [Book] button) to enter first page of Book for Current Record. Press [Stop2] and [Stop3] button simultaneously to clear the data of this page. The total records (second page) for from initial operation remain unchanged by this function.

MACHINE LAYOUT

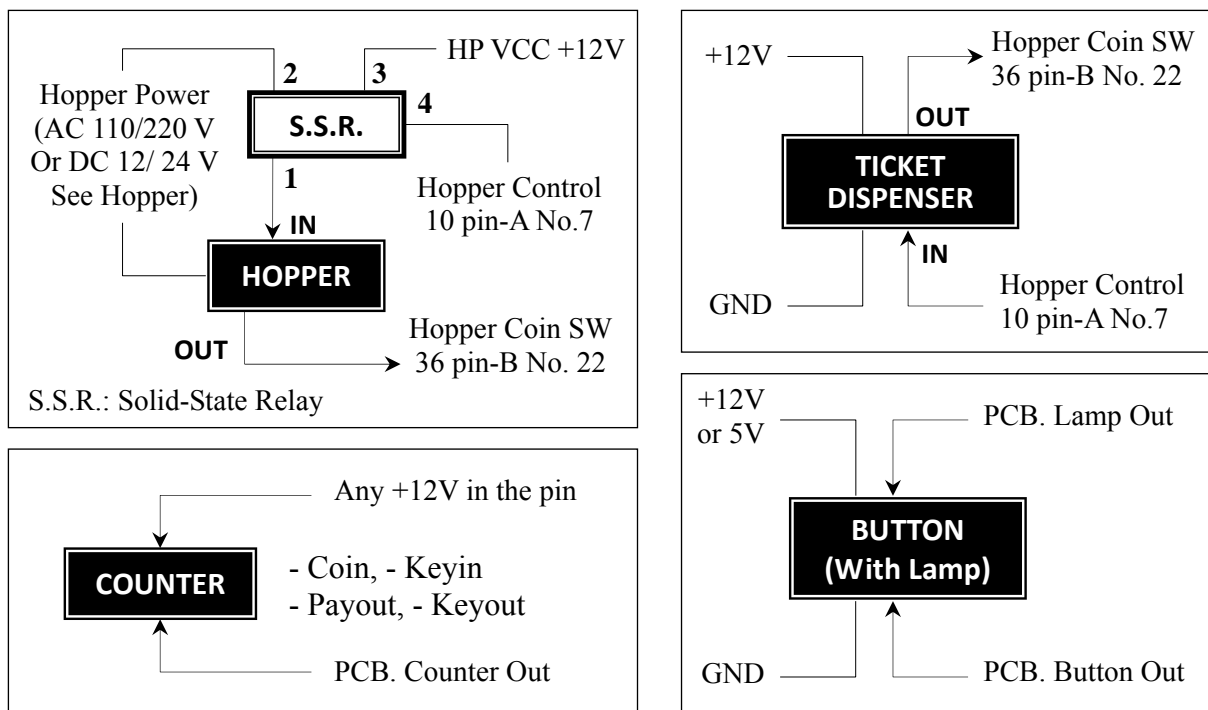

ICT BILL ACCEPTOR - CONNECTOR – CN#1

PIN#1 (Red)	- To PCB +12V
PIN#2 (Orange)	- To PCB GND
PIN#3 (Yellow)	- To PCB +12V
PIN#4 (Green)	- To PCB BILL GND (36 Pin Side A, #34)
PIN#5 (Blue)	- To PCB BILL (36 Pin Side A, #15)
PIN#6 (Purple)	- Unused

ERROR MESSAGE

MESSAGE	DESCRIPTION
System Error	The system may a little confusion instantly. Please do Reset function.
Coin Jam	Power off. Remove the jammed coin from coin selector and power on again. For general error (without jam), press directly “Reset Error” button.
Hopper Jam	Power off. Remove the jammed coin from the hopper and power on again. For general error (without jam), press directly “Reset Error” button.
Hopper Empty	Hopper without Coins/Tokens. Please power OFF and insert Coins/Tokens then power ON again.

TROUBLESHOOTING

SITUATION	FIX
Coin Error	Check coin switch, coin selector and wire wrong.
No sound	<ul style="list-style-type: none"> ● Check the wire of (R+:R-) and (L+:L-) of J3. Two Speaker GND need to be wired separately and don't use same ground. ● Check “Volume setup” on setup page whether close or not.
The counter doesn't work	Check the +12V DC (or +5V DC) line of the counter wire. The wires sometimes are not linked together 10 pin edge connector side of hardness. Please re-wire.
Malfunction of the button, switch and lamps	Check the GND wire. The button, Switch GND has to wire with common GND. Or, check micro switch of button is too old or dirty and the lamp whether out of order.
Coin or Keyin with wrong value	<ul style="list-style-type: none"> ● Check Coin and Keyin wire. Keyin SW port may wire to Coin SW or Bill Acceptor and so on. Please re-wire to correct port. ● Check Game Setup.
Test/ Setup unavailable	Check connection of GND wire between “Test/ Setup” line and common GND line. The GND wire needs to connect with other common GND line.
The Monitor unregulated or Wavy	Adjust the brightness, size and so on as described in the monitor's manual.
Touch Screen doesn't react	<ul style="list-style-type: none"> ● Check Touch Panel is 3M Microtouch or compatible. ● Check the connector of touch screen link exactly to DP3 – Touch Panel port. ● Check Touch Screen function in Game Setup B of Test/ Setup set to “Enable” to activate. And then, power Off and On again to ensure the setup is available.

CONNECTOR DIAGRAM

PIRATE QUEEN (Standard)

COMPONENT SIDE A	36 PIN	SOLDER SIDE B
	1	
	2	
	3	
Stop1	4	
Stop2	5	
Stop3	6	
Stop4	7	
	8	
Stop5	9	
Bet	10	
Max. Bet	11	
Attendant	12	
Start	13	
Help	14	
Bill	15	
Clear Error	16	
	17	
Coin	18	Keyin
Door Alarm	19	
Book	20	Test/ Setup SW
Payout	21	Keyout SW
HP Full SW	22	Hopper Coin SW ⁽¹⁾
Coin Counter	23	Attendant Lamp
Keyin Counter	24	
	25	
Bill in Counter	26	
Payout Counter	27	
Keyout Counter	28	Door Open Lamp
Stop1 Lamp	29	Bet Lamp
Stop2 Lamp	30	Max Bet Lamp
Stop3 Lamp	31	Start Lamp
Stop4 Lamp	32	Help Lamp
Stop5 Lamp	33	Max. Win Lamp
Bill Inhibit	34	Coin Inhibit
HP Full Out	35	
GND	36	GND

COMPONENT SIDE A	10 PIN	SOLDER SIDE B
GND	1	GND
GND	2	GND
+5V	3	+5V
+5V	4	+5V
+12V	5	+12V
	6	
⁽²⁾ Hopper Control	7	HP VCC ⁽³⁾
	8	
GND	9	GND
GND	10	GND

⁽¹⁾ Hopper Coin SW: Out signal for Hopper

⁽²⁾ Hopper Control: In signal for Hopper

⁽³⁾ HP VCC - (DC+12V)

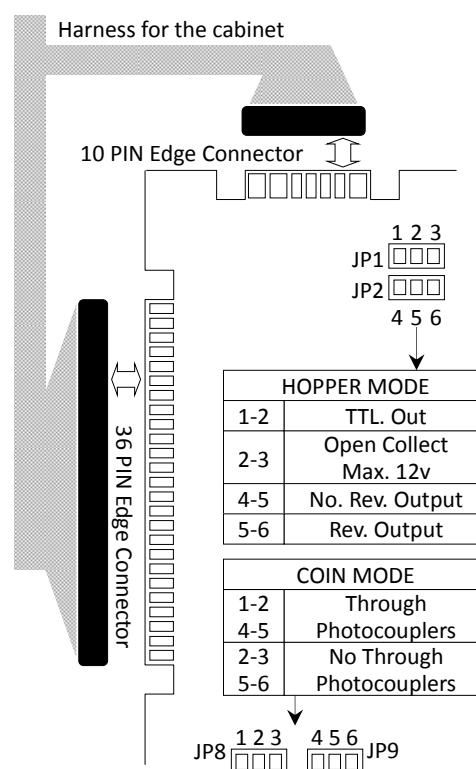

- Clear Error button: To correct instantly the message of “Coin Error”, “Coin Jam” and “Hopper Jam” etc after fix.